

- The Phocas range of top & side hung friction stays
- Lifetime Guarantee*
- Uniquely fitted end cap with an active compression spring to give the ultimate seal every time the window is used offering trouble free installation
- BBA Approved
- 13 & 17mm stack heights suitable for all popular profiles

Technical Information

Assessment Data

Performance: cycle tested to over 25,000 operations and tested to BS 6375 Pt.1:2004 & Pt 2:1987

Corrosion resistance: meets requirements of BS EN 1670:2007 grade 5

BBA Test Report No: 2812

Material Specifications

Track, link and rivets: 430 grade stainless steel (ref BS1449 Part 2:1991)

Metal End Cap: Zinc BS1004A

Plastic Components: Glass reinforced Nylon

Additional Information

Box Quantity: See chart overleaf

Accessories: Hinge Jigs (page 34), Anti-Jemmy & Child Restrictor (see page 37)



PICTURE SHOWS HIGH STACK VARIANT



With its Active Compression Technology (ACT), the new Phocas friction stay ensures accurate installation and realignment of the sash and frame, to create the perfect seal with peace of mind and ease of fabrication.

*Applicable to the life of the installed window and subject to Avocet's mechanical warranty and maintenance instructions.



REPORT NO: 2812

PHOCAS FRICTION STAY - DIMENSIONS

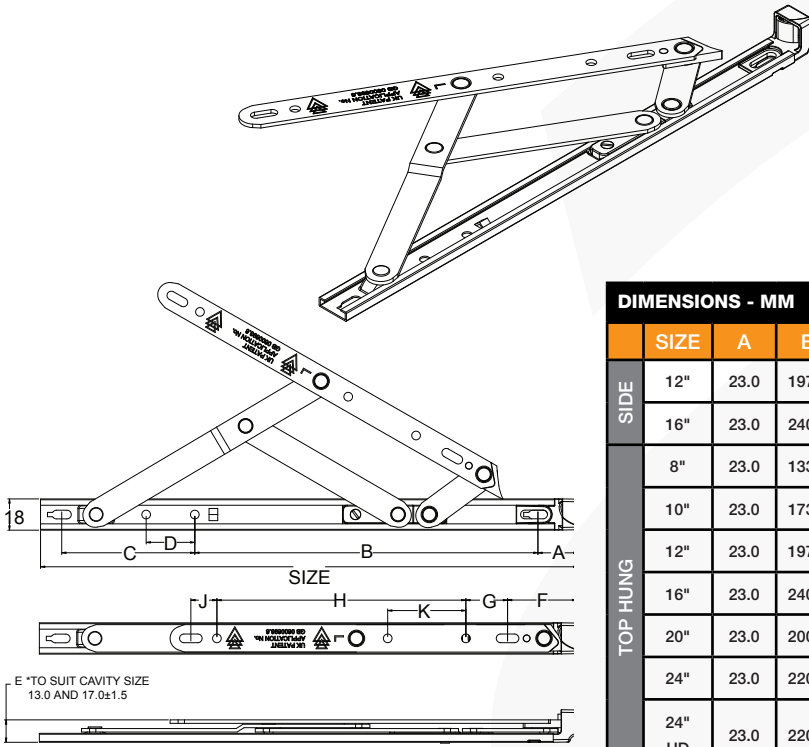

DIMENSIONS - MM											
	SIZE	A	B	C	D	E	F	G	H	J	K
SIDE	12"	23.0	197.5	76.5	76.5	13/17	40.0	59.0	108.5	15.0	-
	16"	23.0	240.5	134.0	66.5	13/17	40.0	24.0	198.0	24.0	94.5
TOP HUNG	8"	23.0	133.5	42.0	-	13/17	41.5	12.0	95.5	15.0	-
	10"	23.0	173.5	52.0	-	13/17	41.0	24.0	112.5	15.0	-
	12"	23.0	197.5	76.5	28.0	13/17	40.0	24.0	143.5	15.0	45.0
	16"	23.0	240.5	134.5	66.5	13/17	40.0	24.0	198.0	24.0	94.5
	20"	23.0	200.5	274.5	136.5	13/17	40.0	24.0	246.0	24.0	128.0
	24"	23.0	220.5	354.5	166.5	13/17	40.0	24.0	189.0	131.0	-
	24" HD	23.0	220.5	354.5	166.5	13/17	40.0	24.0	189.0	131.0	95.0

PRODUCT CODES

	PART NO.	STACK HEIGHT		SIZE	OPEN ANGLE (°)	MAX WEIGHT (KG)	MAX VENT SIZE (MM) W X H	BOX QTY
		13mm	17mm					
SIDE HUNG	ASH12P	✓		12	60	22	600 X 1200	50
	AHSH12P		✓	12	60	22	600 X 1200	40
	ASH16P	✓		16	60	24	650 X 1200	25
	AHSH16P		✓	16	60	24	650 X 1200	20
TOP HUNG	ATH08P	✓		8	60	12	1200 X 350	50
	AHTH08P		✓	8	60	12	1200 X 350	40
	ATH10P	✓		10	70	14	1200 X 400	50
	AHTH10P		✓	10	70	14	1200 X 400	40
	ATH12P	✓		12	60	16	1200 X 550	50
	AHTH12P		✓	12	60	16	1200 X 550	40
	ATH16P	✓		16	60	20	1200 X 800	25
	AHTH16P		✓	16	60	20	1200 X 800	20
	ATH20P	✓		20	40	24	1200 X 900	25
	AHTH20P		✓	20	40	24	1200 X 900	20
	ATH24P	✓		24	40	27	1200 X 1000	25
	AHTH24P		✓	24	40	27	1200 X 1000	20
	ATH24PHD	✓		24	40	35	1200 X 1200	25
	AHTH24PHD		✓	24	40	35	1200 X 1200	20

All 90° opening Phocas Friction Stays are available in both a standard and long reach format for maximum compatibility with the majority of uPVC window profiles.

Please refer to the profile list below to aid you in product selection. For dimensions please refer to individual product pages.

PRODUCT OPTIONS			
PROFILE	STACK HEIGHT	LONG REACH	STANDARD REACH
ALUPLAST 60	17MM	✓	
ALUPLAST 70	17MM	✓	
DECEUNINCK 2500	17MM	✓	
DECEUNINCK 2800	17MM	✓	
DECEUNINCK 3000	17MM	✓	
DIPLOMAT 70	13MM		✓
DURAFLEX DIAMOND 65 & 70	13MM		✓
EUROCELL 60mm	13MM		✓
EUROCELL ULTIMATE 70	15MM		✓
EUROCELL LOGIK	17MM	✓	
EUROCELL LOGIK OVALO	17MM	✓	
EUROCELL MODUS	17MM	✓	
HIS 5 STAR	17MM		✓
KBE MARK 5 58mm	13MM		✓
KBE 70	17MM		✓
KOMMERLING 070 GOLD	17MM	✓	
KOMMERLING GOLD 58mm	17MM	✓	
LB6000	17MM	✓	
LB7000	13MM	✓	
LB8000 BEVELLED	17MM	✓	
LB8000 CONTOUR	17MM	✓	
LINEAR SYSTEMS	17MM	✓	
PROFILE 22 FS 70	13MM	✓	
PLASTMO INDEX	17MM		✓
REHAU S706	17MM		✓
REHAU TRITEC	17MM		✓
SELECTA 8000 60MM	17MM	✓	
SELECTA ADVANCE 70	17MM		✓
SPECTUS ELITE 63	17MM		✓
SPECTUS ELITE 70	17MM		✓
STATUS ZENDOW	17MM	✓	
SYNSEAL EVOLVE 60	15MM		✓
SYNSEAL LEGEND 70	15.5MM		✓
SYNSEAL SHIELD	13MM		✓
SYNSEAL SYNERJY	13MM		✓
SWISH TRADITIONAL 70 (H.I.S 5 STAR)	17MM		✓
SWISH 24-7	13MM		✓
VEKA MATRIX 58mm	13MM	✓	
VEKA MATRIX 70mm	13MM	✓	
WHS HALO RUSTIQUE	17MM	✓	
WHS HALO ECLIPSE	17MM		✓
WHS HALO ESTHETIQUE	17MM		✓
WHS HALO SYSTEM 10 62mm	17MM	✓	
WHS HALO SYSTEM 10 70mm	17MM	✓	

